

# Indigo™ Series 1400 Ice Cube Machine

Model:  ID-1402A     ID-1403W     ID-1492N  
 IY-1404A     IY-1405W     IY-1494N



Indigo Series i-1400  
Ice Machine on B-970 Bin

Designed for operators who know that ice is critical to their business, the Indigo™ Series ice machine's preventative diagnostics continually monitor itself for reliable ice production. Improvements in cleanliness and programmability make your ice machine easy to own and less expensive to operate.

- **Space-Saving Design** – Up to 1,550 lbs. (705 kgs.) daily ice production and only 48" (121.92 cm) wide.
- **Intelligent Diagnostics** – provide 24 hour preventative maintenance and diagnostic feedback for trouble free operation.
- **Acoustical Ice Sensing Probe** – for reliable operation in challenging water conditions.
- **EasyRead Display** – communicates operating status, cleaning reminders, and asset information through a blue illuminated display.
- **Programmable Ice Production** – by On/Off Time, Ice Volume or Bin Level (with accessory bin level control) further improves energy efficiency and savings.
- **Easy to Clean Foodzone** – Hinged front door swings out for easy access. Removable water-trough, distribution tube, curtain, and sensing probes for fast and efficient cleaning. Select components made with AlphaSan® antimicrobial.
- **DuraTech™ Exterior** – provides superior corrosion resistance. Stainless finish with innovative clear-coat resists fingerprints and dirt.
- Available **LuminIce™ Growth Inhibitor** controls the growth of bacteria and yeast within the foodzone.

## Ice Machine Electric

208-230/60/1 standard  
(208-230/60/3 and 230/50/1 also available.)

### Minimum circuit ampacity:

Air-cooled:	18.3 1ph	13.2 3ph
Water-cooled:	16.9 1ph	11.8 3ph
Remote-cooled:	17.9 1ph	12.8 3ph

### Maximum fuse size:

Air-cooled:	30 1ph	20 3ph
Water-cooled:	30 1ph	20 3ph
Remote-cooled:	30 1ph	20 3ph

## Specifications

### BTU Per Hour:

23,500 (average)  
27,000 (peak)

### Refrigerant:

R-404A CFC-free

### Operating Limits:

- Ambient Temperature Range: 35° to 110°F (1.7° to 43.3°C)  
Water Temperature Range: 35° to 90°F (1.7° to 32.2°C)
- Water Pressure Ice Maker Water In: Min. 20 psi (137.9 kPa)  
Max. 80 psi (551.1 kPa)



## Ice Shape



**Half Dice**  
3/8" x 1 1/8" x 7/8"  
(.95 x 2.86 x 2.22 cm)



**Dice**  
7/8" x 7/8" x 7/8"  
(2.22 x 2.22 x 2.22 cm)



COMPANY WITH  
QUALITY SYSTEM



# Indigo™ Series 1400 Ice Cube Machine

## i-1400 on B-970 Storage Bin

### Installation Note

*Air Cooled clearance:*

Top: 24" (61.0 cm)

Sides: 24" (61.0 cm)

Back: 5" (30.5 cm)

*Water Cooled clearance:*

Top/Sides: 8" (20.3 cm)

Back: 5" (12.7 cm)

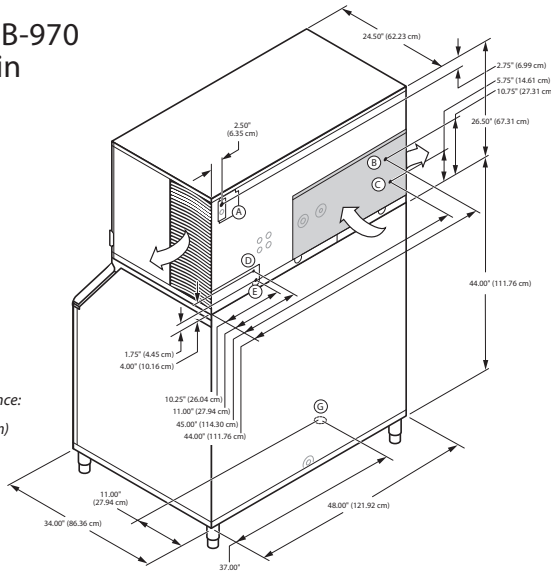

- Ⓐ Electrical Entrance (2) Options
- Ⓑ 1/2" (1.27 cm) F.P.T. Water Condenser Outlet (water-cooled units)
- Ⓒ 3/8" (0.95 cm) F.P.T. Water Condenser Inlet (water-cooled units)
- Ⓓ 3/8" (0.95 cm) F.P.T. Ice Making Water Inlet
- Ⓔ 1/2" (1.27 cm) F.P.T. Ice Making Water Drain
- Ⓜ 1/2" (1.27 cm) Auxillary Base Drain Socket
- Ⓝ 3/4" (1.91 cm) Bin Drain
- ⇨ Air flow for air-cooled models

## Space-Saving Designs



### i-1400 B-970

Height	76.50" 194.31 cm
Width	48.00" 121.92 cm
Depth	34.00" 86.30 cm
Bin Storage	710 lbs. 322.2 kgs.

*Height includes adjustable bin legs 6.00" to 8.00", (15.24 to 20.32 cm) set at 6.00" (15.24 cm).*

## Specifications

	Model	Ice Shape	Ice Production 24 Hours		Power Usage kWh/100 lbs. @90° Air/70°F		Water Usage/ 100 lbs. 45.4 kgs. of Ice	ENERGY STAR®
			70° Air/ 50°F Water	90° Air/ 70°F Water	1 Ph	3 Ph	Potable Water	
AIR-COOLED	ID-1402A	dice	1,500 lbs. 682 kgs.	1,155 lbs. 525 kgs.	4.86	4.86	23.5 gal. 89 L.	
	IY-1404A	half-dice	1,550 lbs. 705 kgs.	1,180 lbs. 536 kgs.	4.88	4.88	23.5 gal. 89 L.	
WATER-COOLED	ID-1403W	dice	1,515 lbs. 689 kgs.	1,275 lbs. 580 kgs.	3.85	3.85	23.5 gal. 89 L.	NA
	IY-1405W	half-dice	1,565 lbs. 711 kgs.	1,290 lbs. 586 kgs.	3.86	3.86	23.5 gal. 89 L.	NA
* Water-cooled Condenser Water Usage / 100 lbs. / 45.4 kgs. Of Ice: 154 gal. / 583 L. * Water-cooled models are excluded from ENERGY STAR qualification.								
REMOTE-COOLED	ID-1492N	dice	1,430 lbs. 650 kgs.	1,220 lbs. 555 kgs.	4.52	4.52	23.5 gal. 89 L.	
	IY-1494N	half-dice	1,480 lbs. 673 kgs.	1,230 lbs. 559 kgs.	4.53	4.53	23.5 gal. 89 L.	

*Order ice storage bin separately. To order 3 phase add "3" suffix to model # (ID-1202A3).*

## Accessories

**LuminIce™ Growth Inhibitor**  
reduces yeast and bacteria growth for a cleaner ice machine.



**Bin Level Control**  
Allows ice bin level to be automatically set. Built-in LED light illuminates bin.



**Arctic Pure® Water Filters**  
Reduces sediment and chlorine odors for better tasting ice.



**AuCS®**  
schedules and performs routine ice machine cleaning automatically.

