

Indigo™ Series 300 Ice Cube Machine

Model: ID-0302A IY-0304A ID-0303W IY-0305W



Indigo Series i-300
Ice Machine on B-170 Bin

Designed for operators who know that ice is critical to their business, the Indigo™ Series ice machine's preventative diagnostics continually monitor itself for reliable ice production. Improvements in cleanability and programmability make your ice machine easy to own and less expensive to operate.

- **Space-Saving Design** – Up to 310 lbs. (141 kgs.) daily ice production and only 30" (76.20 cm) wide.
- **Intelligent Diagnostics** – provide 24 hour preventative maintenance and diagnostic feedback for trouble free operation.
- **Acoustical Ice Sensing Probe** – for reliable operation in challenging water conditions.
- **EasyRead Display** – communicates operating status, cleaning reminders, and asset information through a blue illuminated display.
- **Programmable Ice Production** – by On/Off Time, Ice Volume or Bin Level (with accessory bin level control) further improves energy efficiency and savings.
- **Easy to Clean Foodzone** – Hinged front door swings out for easy access. Removable water-trough, distribution tube, curtain, and sensing probes for fast and efficient cleaning. Select components made with AlphaSan® antimicrobial.
- **DuraTech™ Exterior** – provides superior corrosion resistance. Stainless finish with innovative clear-coat resists fingerprints and dirt.
- Available **LuminIce™ Growth Inhibitor** controls the growth of bacteria and yeast within the foodzone.

Ice Machine Electric

115/60/1 standard.
(208-230/60/1 and 230/50/1 also available.)

Minimum circuit ampacity:

Air-cooled: 10.8
Water-cooled: 10

Maximum fuse size:

15 amps 1ph

Specifications

BTU Per Hour:

4,600 (average), 5,450 (peak)

Refrigerant:

R-404A CFC-free

Operating Limits:

- Ambient Temperature Range: 35° to 110°F (1.7° to 43.3°C)
Water Temperature Range: 35° to 90°F (1.7° to 32.2°C)
- Water Pressure Ice Maker Water In:
Min. 20 psi (137.9 kPa)
Max. 80 psi (551.1 kPa)



Ice Shape



Half Dice
3/8" x 1 1/8" x 7/8"
(.95 x 2.86 x 2.22 cm)



Dice
7/8" x 7/8" x 7/8"
(2.22 x 2.22 x 2.22 cm)





Indigo™ Series 300 Ice Cube Machine

i-300 on B-170 Storage Bin

Installation Note
Water Cooled clearance:
 Top/Sides: 8" (20.3 cm)
 Back: 5" (12.7 cm)

Air Cooled clearance:
 Top/Sides: 16" (40.6 cm)
 Back: 5" (12.7 cm)

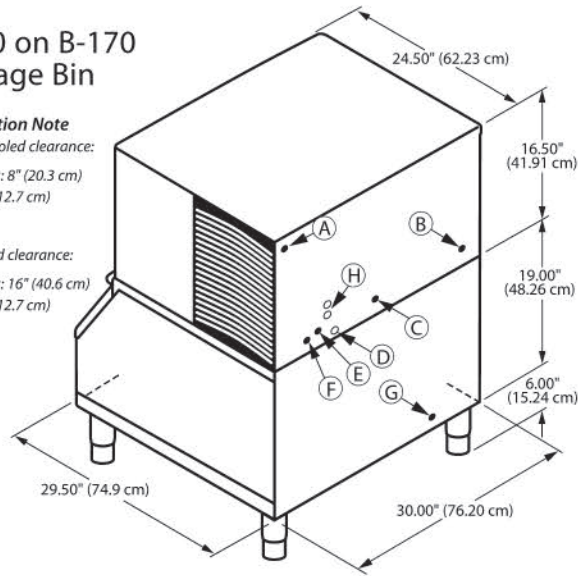

- (A) Electrical Entrance
- (B) 3/8" (0.95 cm) F.P.T. Water Condenser Inlet (water-cooled units)
- (C) 1/2" (1.27 cm) F.P.T. Water Condenser Outlet (water-cooled units)
- (D) 1/2" (1.27 cm) Auxiliary Base Drain Socket
- (E) 3/8" (0.95 cm) F.P.T. Ice Making Water Inlet
- (F) 1/2" (1.27 cm) F.P.T. Ice Making Water Drain
- (G) 3/4" (1.91 cm) Bin Drain

Space-Saving Designs



	i-300 B-170	i-300 B-400
Height	41.50" 105.41 cm	54.50" 138.43 cm
Width	30.00" 76.20 cm	30.00" 76.20 cm
Depth	29.50" 74.93 cm	34.00" 86.30 cm
Bin Storage	150 lbs. 68.04 kgs.	290 lbs. 131.50 kgs.

Height includes adjustable bin legs 6.00" to 8.00", (15.24 to 20.32 cm) set at 6.00" (15.24 cm).

Specifications

	Model	Ice Shape	Ice Production 24 Hours		Power Usage kWh/100 lbs. @90°Air/70°F	Water Usage/ 100 lbs. 45.4 kgs. of Ice	ENERGY STAR*
			70°Air/ 50°F Water	90°Air/ 70°F Water			
AIR-COOLED	ID-0302A	dice	310 lbs.	225 lbs.	7.48	24.9 Gal.	★
			141 kgs.	102 kgs.		94.3 L	
	IY-0304A	half-dice	310 lbs.	235 lbs.	7.38	24.9 Gal.	★
			141 kgs.	107 kgs.		94.3 L	
WATER-COOLED	ID-0303W	dice	300 lbs.	260 lbs.	5.69	24.9 Gal.	NA
			136 kgs.	118 kgs.		94.3 L	
	IY-0305W	half-dice	300 lbs.	260 kgs.	5.69	24.9 Gal.	NA
			136 kgs.	118 kgs.		94.3 L	

* Water-cooled Condenser Water Usage / 100 lbs. /45.4 kgs. Of Ice: 193 gal/731 L.
 * Water-cooled models are excluded from ENERGY STAR qualification.

Order ice storage bin separately.

Accessories

LuminIce™ Growth Inhibitor
 reduces yeast and bacteria growth for a cleaner ice machine.



Bin Level Control
 Allows ice bin level to be automatically set. Built-in LED light illuminates bin.



Arctic Pure® Water Filters
 Reduces sediment and chlorine odors for better tasting ice.



AuCS®
 schedules and performs routine ice machine cleaning automatically.



2110 South 26th Street
 PO Box 1720
 Manitowoc, WI 54221-1720 USA

Tel: 1.920.682.0161
 Fax: 1.920.683.7589
www.manitowocice.com



Mixed Sources
 Product group from well-managed forests, controlled sources and recycled wood or fiber.
 www.fsc.org Cert no. SW-COC-001886
 © 1996 Forest Stewardship Council

