



SM-50 Ice Cube Machine

Model

SM-50A



SM-50



Standard Features

- Produces up to 53 lbs. (24 kgs) of ice in 24 hours with storage capacity of 25 lbs. (11 kgs)
- Individual cubes with unique octagon shape.
- Designed to be installed into standard cabinet dimensions 15.00" (38.00 cm) or stand alone with stainless steel top and sides standard.
- Unit ships with hinge on right, easily changed to left during installation.
- Easily accessible control panel with the following functionality:
 - Automatic ice making mode.
 - Patented cleaning and sanitizing.
 - Delay start option.
 - Filter replacement warning light.
- Water filter system integrated inside machine with depth filtration and scale inhibitor.
- Lighted bin (LED light) with large opening for easy access.
- Optional drain pump easily integrates inside the machine during installation.

Warranty

- 3-year commercial parts and labor warranty on entire machine.
- 1-year residential ice machine limited warranty.

Cube Size

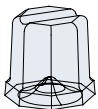

Standard
1 3/8" x 1 3/8"
(33 x 34 mm)





SM-50 Ice Cube Machine

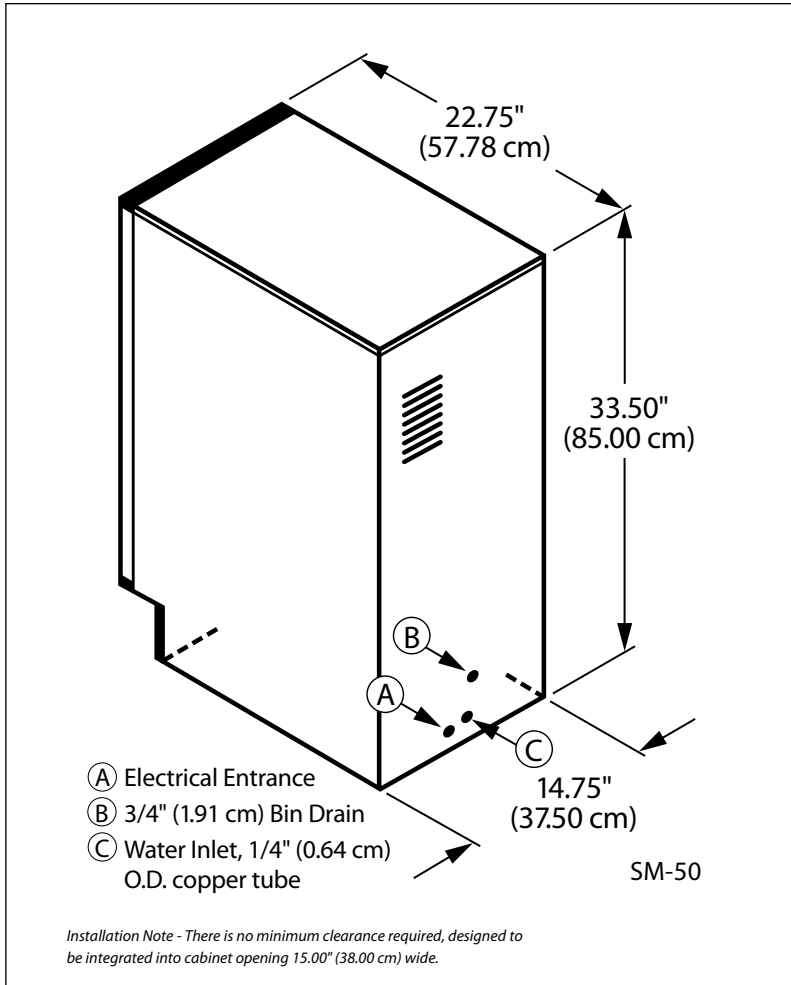

Ice Machine Electric

115/60/1 Factory pre-wired with a 6' (180 cm) power cord and NEMA 5-15P-plug configuration.

Total Amps: 4.1

Max. fuse size: 15 amps

HACR-type circuit breakers can be used in place of fuses.

Specifications

BTU Per Hour:

1,145 (average) 2,300 (peak)

Compressor:

Nominal rating: 1/6 HP

Operating Limits:

- Ambient Temperature Range: 50° to 110°F (10° to 43°C)
- Water Temperature Range: 35° to 90°F (2° to 32°C)
- Water Pressure Ice Maker Water In: Min. 20 psi (138 kPa) Max. 80 psi (551 kPa)

Legs:

Levelers standard 0" to 1" (0-2.5 cm) adjustability.

Optional legs (K-00345) 4.25"-6.00" (10.80-15.24 cm).

Insulation:

Insulation foamed-in-place with CFC-FREE foam.

Model	Ice Shape	Ice production 24 hours				Power kWh/100 lbs @90°/70°F
		70° Air/50° F Water 21° Air/10° C Water		90° Air/70° F Water 32° Air/21° C Water		
		lbs.	kgs	lbs.	kgs	
SM-50A	Standard	53	24	44 lbs.	20 kgs	7.0
Water usage/100 lbs./45.4 kgs of Ice						
Potable Water: 43 gallons, 163 liters						

"A" following model number indicates "Air" cooled condensing unit.

Air Flow Front View

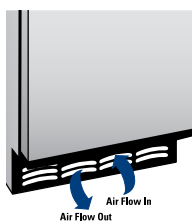

Air in right, air out left, no side vents.

Front Access Control Panel



Machine automatically keeps the bin full. Choose delay start for optimal quietness. Machine automatically restarts.

Water Filter



Auto-bypass for easy change out. Replacement water filter is AR-2800 (K-00374 12 pk).